**COGENT***"ALWAYS COMPLETE"*

Cogent Computer Systems, Inc.

17 Industrial Drive, Smithfield RI 02917**tel: 401-349-3999, fax: 401-349-3998, web: www.cogcomp.com**

CSB1725-MV78200 System On a Module (SOM)

The CSB1725-MV78200, designed, developed and manufactured by Cogent Computer Systems, Inc., is a high performance, network oriented, ARMv5TE based System on a Module (SOM). The CSB1725-MV78200 provides a small, powerful and flexible engine for embedded Linux based 10/100/1000 networking and storage applications.

Specifications and Features

CPU - 1Ghz Dual Superscalar ARMv5TE Cores (800Mhz Single Core Option - MV78100)

CACHE - 32KByte Instruction and Data Caches; 512KByte L2 Cache

FPU - IEEE 754 Compliant Single/Double Precision Floating Point Unit

SDRAM - 512MByte (1GByte Option) 64-Bit Wide DDR2-533 Memory with 8-Bit ECC

FLASH - On-Board 64MByte NOR w/Secure Silicon ID and 512MByte SLC NAND

PCI EXPRESS - One x4 Link (or four x1's) and Two x1 Links

GIGABIT ETHERNET - Two 10/100/1000 ports via 88E1121R Dual RGMII to Copper PHY

SECURITY - On-Chip Cryptographic and Security Acceleration Engines Support Various Encryption/Decryption Algorithms: AES128; DES/3DES; MD-5 and SHA1 hashing; and others

XOR/RAID - High Speed XOR DMA Engine for RAID Storage Applications

SATA - Dual SATA Gen 2 (1.5Gbit or 3Gbit/sec) Channels

USB - Two 480Mbit USB 2.0 Host Ports via Built-In PHY

SERIAL I/O - Four 4-wire TTL Serial Ports, Two I2C Port and one SPI Port

JTAG - Standard ARM JTAG (Header located off module)

OPERATING VOLTAGE - 12V Input Rail; On-Board 3.3V (for I/O with 3 Amp available to off board devices), 1.8V (SDRAM), 1.0V (CPU Core) Power Supplies

POWER MANAGEMENT - On-Board ATXMEGA Microcontroller for Power Sequencing, Boot Configuration, FAN Control and Thermal Monitoring

OPERATING TEMPERATURE - 0C to +70C Standard, -20C to +85C Option

POWER CONSUMPTION (DUAL CORE) - 8W typ., 12W Max and <10mw Power Down

COGENT MXM SOM COMPLIANT - Common, Interchangeable Footprint across Multiple CPU Architectures (x86, PowerPC, MIPS and ARM); Uses Low Cost Industry Standard MXM-II Socket

ULTRA COMPACT SIZE - 70mm x 75mm x 4.2mm (height does not include socket standoff height)

BOOTLOADER AND OS SUPPORT - Uboot and Linux 2.6.37+

Introduction and Overview

The Dual Superscalar Sheeva ARMv5TE Architecture Cores, multiple PCI Express links, high speed USB, Dual Serial ATA, Dual 10/100/1000 Ethernet, and highly efficient on-board regulators all combine to make the CSB1725-MV78200 the ideal engine for size restricted, high performance, Network and Storage applications. For the lowest power consumption, the IPM Micro can power the board down completely while remaining on standby power. In this mode the consumption drops to <10milliwatts with IPM bus wakeup events still active. The IPM Micro also controls power sequencing; thermal and voltage monitoring; FAN Control; and boot configuration.

The CSB1725-MV78200 is constructed using state of the art PCB layout and packaging technology such as: 533Mhz DDR2 balanced tree routing; 3GHZ+ high-speed differential signaling; 15 Amp peak switching regulators; and 8-layer, low EMI, impedance controlled PCB stackup. The CSB1725-MV78200 gives you access to this technology without the learning curve or the risk. You can integrate the CSB1725-MV78200 using a simple, low cost 4-layer PCB, in just weeks, not months! We can even do it for you through our custom design services group.

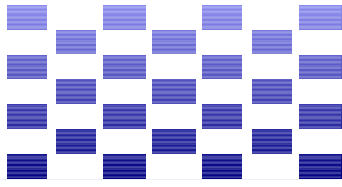

COGENT

"ALWAYS COMPLETE"

Cogent Computer Systems, Inc.

17 Industrial Drive, Smithfield RI 02917

tel: 401-349-3999, fax: 401-349-3998, web: www.cogcomp.com

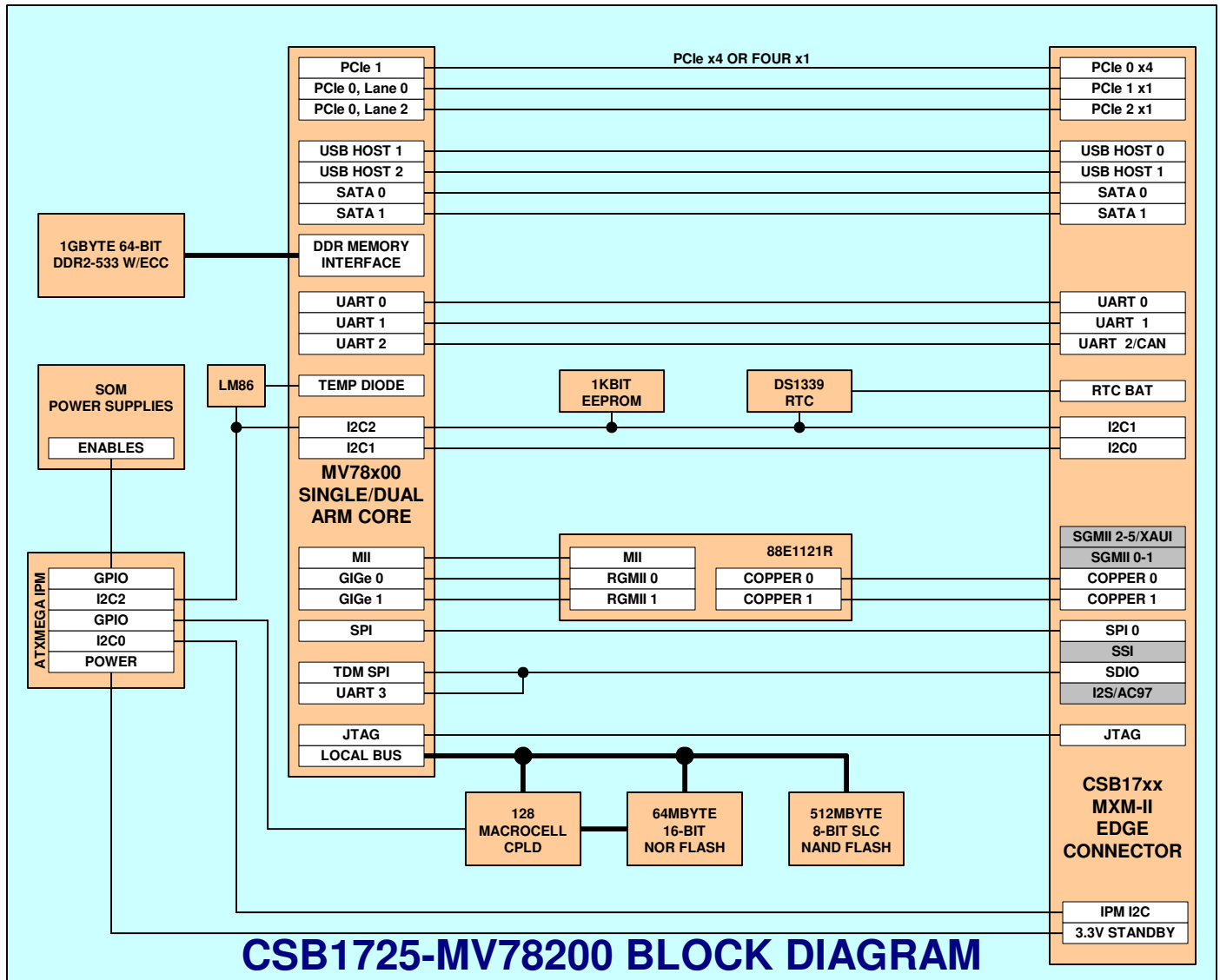

CSB1725-MV78200 BLOCK DIAGRAM

Development Boards and I/O Expansion

The CSB1725-MV78200 is fully compatible with the CSB1701 Flex-ATX Development Platform. This platform provides a CSB17xx compatible MXM-II Socket; One PCIe x16 Edge Card Socket (x4 mode only with CSB1725-MV78200); Two PCIe x1 Sockets; CPU I/O Expansion Headers; USB to RS-232 COM Port; Dual 10/100/1000 Ethernet; Dual SATA Connectors; Four USB Host Connectors; SD/MMC Socket; and 20-pin JTAG Header. The KIT1725-MV78200 consists of the CSB1725-MV78200 and CSB1701, USB-Serial and Ethernet Cables, with an optional Small Form Factor (SFF) Case and Power Supply. Contact Cogent for more detailed information about the CSB1725-MV78200, CSB1701 and the KIT1725-MV78200.